

Boomer L2

Hydraulically controlled face drilling rig with a coverage area up to 104 m²



Fast and efficient face drilling

The Boomer L2 is a powerful hydraulically controlled face drilling rig for mining and tunnelling. It is equipped with two BUT 35 heavy-duty booms that offer quick and easy positioning. The burly booms boost your productivity by helping you achieve your advance-rate goals, regardless of local ground conditions.

⊕ Main benefits

Robust and dependable thanks to components crafted for extreme durability and systems based on standard parts

Outstanding drill economy with rock drill options like COP 1638HD+, COP 1838HD+ or COP 2238HD+ which offer dual damping and remarkable longevity

Safety and control with excellent visibility thanks to the FOPS certified telescopic protective roof or the comfortable, ergonomically designed FOPS and ROPS certified cabin

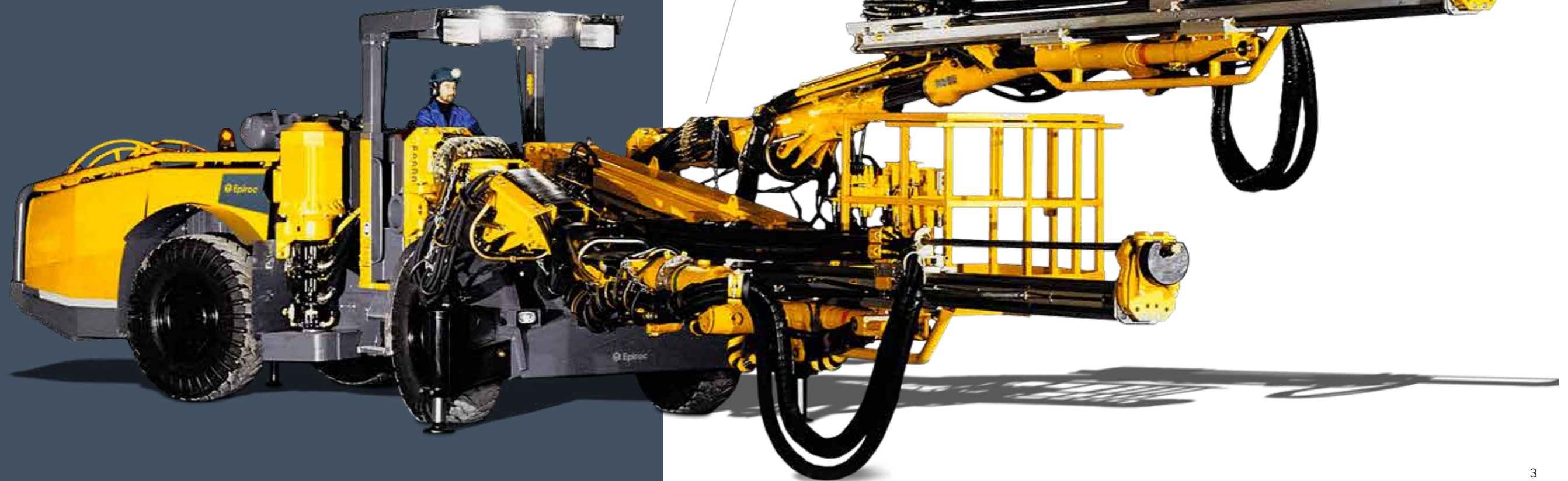

Dual BUT 35 booms offer fast and easy positioning

COP rock drills feature dual damping for high-speed drilling and greater drill steel longevity

BMH 6000-series aluminium feed with high bending and torsional resistance

Advancements to help you progress

With its hydraulic-controlled drilling system, the forceful Boomer L2 clears the way to help you keep on the advance in your mining and tunnelling operation. Hard-wearing COP rock drills provide excellent penetration rates in any rock conditions.



+ Easy to operate and maintain

Boomer L2's ergonomically designed cabin creates an ideal operator environment. A user-friendly control interface enables the operator to easily monitor and control all functions of the rig to maintain an optimal workflow. The robust Boomer L2 is also designed for ease of maintenance with easy access to all service points.



+ Performance and flexibility

The Boomer L2 is powered by a 4-cylinder diesel engine that combines powerful performance with low emissions for a lower environmental impact. The rig's diesel-driven hydraulic power source provides outstanding flexibility. Engines are available as stage III A approved.



+ Cop 1800HD+ series hydraulic rock drills

Rock drills in the COP 1800HD+ series are hard wearing, and the engine has been crafted so you can enjoy long intervals between overhauls. The separate lubrication of driver and gear as well as pressurized side bolts and mating surfaces help to ensure reliable operation and low maintenance costs. The powerful stepless and reversible rotation motor ensures high torque with variable speed control to better adapt to changing work conditions.



A comprehensive service offering

Even the best equipment needs to be serviced regularly to make sure it sustains peak performance. An Epiroc service solution offers peace of mind, maximizing availability and performance throughout the lifetime of your equipment. We focus on safety, productivity and reliability.

By combining genuine parts and an Epiroc service from our certified technicians, we safeguard your productivity – wherever you are.

Technical specifications

● - Standard ○ - Option

Drilling system

COP 1638HD+	○
COP 1838HD+	●
COP 2238HD+	○
Air-water mist flushing: External air and water supply, oil cooled by water, external air and water supply, oil cooled by air fan, internal air and water supply, oil cooled by water, internal air and water supply, oil cooled by air fan	○
Big hole drilling system	●

Boom

BUT 35 M	●
BUT 35 L	○
Service platform P2	○
Automatic boom lubrication kit, rear part of boom	○

Feed

BMH 6800-series 14 ft, 16 ft, 18 ft, 21 ft	●
BMHS 6800-series 14 ft	○
Telescopic feed BMHT 6000-series	○
Extension drilling set BSH 110 (BMH feeds only)	○
Feed prepared for RAS	○
Rod Adding System, RAS	○
Mining (heavy duty) drilling centraliser	○

Air/water system

Hydraulically driven screw compressor: Epiroc GAR 5	●
Hole blowing kit with 80 l air receiver	○
Compressor, GAR 30	○
Water booster pump: capacity at 15 bar: 250 l/min	●
Min water inlet pressure at 200 l/min at preferred pressure of 2 bar	●
Water hose reel	○

Hydraulic system

Low oil level indicator	●
Oil temperature gauge on oil tank	●
Electrical oil filling pump	●
Oil filter indicator	●
Water cooled oil	●
Filtration: 16 µm	●
Mineral hydraulic oil	●

Control system

Direct Control System (DCS)	●
Pilot Control System (PCS/DCS 2)	○
Feed Angle Measurement system, FAM 1	○
Feed angle measurement system with drill plan handling and navigation, FAM 3	○
CertiQ - telematics system	○
Drill stop protection system (CE certified)	○

Add-on options

Hydraulic Swellex pump	○
Rig washing kit with water hose and reel	○
Boot washing kit	○
Hose/cable guiding at water/cable reel	○

Electrical system

Total installed power: 158 kW	●
Main motors: 2x75 kW	●
Voltage: 380-1 000 V	●
Frequency: 50-60 Hz	●
Starting method: star/delta (1 000 V direct start)	●
Starting method: DOL (1 000 V)	○
Electronic overload protection for electric motors	●
Percussion hour meter on operator display	●
Digital voltmeter/ampere meter in electric cabinet	●
Phase sequence indicator	●
Earth fault indicator	●
Battery charger	●
Transformer: 8 kVA	●
Working lights, halogen: 2x1 000 W	○
Cable reel, diameter: 1 600 mm	●
Dual controls for cable reel	●
Stainless steel electrical enclosure	○
Electric cable type H07RN-F or Buxflex	○
Plug for cable	○
Switch gear	○
Electric outlet for accessories, 16 A (CE and not for 1 000 V)	○
Extra transformer 3-phase, 15 kVA, 230/400 V	○
Starting method - soft start (not for 1 000 V)	○

Carrier

Deutz 4-cylinder, TCD 2013 LO4, EPA III/COM III (Tier 3/Stage IIIA) approved 4-stroke prechamber diesel engine	●
Power rating at 2 300 rpm: 120 kW (160 hp)	●
Articulated steering: ±38° steering angle	●
Fixed seat for tramping	●
Four-wheel drive	●
Hydrostatic power steering system	●
Hydrodynamic transmission: Clark 24000	●
Front axle: Dana 114	●
Rear axle: Dana 114, ±8° oscillation	●
Automatic differential lock on front axle, limited slip	●
Tyres: 14xR24	●
Tyres: 14xR24, foam filled	○
Clearance outside axles: 19' front, 14' rear	●
Hydraulic jacks, front: 2 extendable	●
Hydraulic jacks, rear: 2	●
Service brakes: 2 separate circuits	●
Emergency and parking brakes: SAHR	●
Fuel tank, volume: 100 l	●
Exhaust catalyser	●
Silencer	●
Electric system: 24 V	●
Batteries: 2x12 V, 125 Ah	●
Tramping lights: 6x40 W 24 V LED, 2x70 W halogen	●
Working lights: 4x80 W LED, 24 V DC	●
Brake lights	●
Fire extinguisher	●
Central lubrication system	●
Gradeability at max. load on drive wheels: 14	●
Horn, beacon and reverse alarm	●
Shelf for drill bits and tools	●
Fire suppression system AN SUL (manual/automatic)	○
Heater kit for hydraulic oil tank, diesel engine and electric motors	○

Drifter rods

Rock drill	Rod	Min. hole diameter (mm)
COP 1638HD+ COP 1838HD+ COP 2238HD+	R32-H35-R38	45
	R32-H35-T38	45
	R32-H35-T38 Speedrod	45
	SR35-H35-R38 Speedrod	45
	SR35-H35-T38 Speedrod	45
	SR35-H35-T38	45
	SR35-R39-T38	45
	R32-R39-T38	45
	SR35-R39-T38	45
	SR35-R39-T38 Speedrod	45

Extension rods for injection drilling/RAS

Rock drill	Rod	Min. hole diameter (mm)
COP 1638HD+ COP 1838HD+ COP 2238HD+	Rnd 32 Speedrod	51
	Rnd 38 Speedrod	64

Shank adapters

Rock drill	Rod	Min. hole diameter (mm)	Length
COP 1638HD+ COP 1838HD+ COP 2238HD+	R38	38	435
	T38	38	435
	R32	38	525
	T38*	38	525

* Intended for RAS and extension drilling with BSH 110

Protective roof

Manual spotlight, left and/or right	<input type="checkbox"/>
-------------------------------------	--------------------------

Couplings

Rock drill	Rod	Diameter (mm)	Length (mm)
COP 1638HD+	R38	55	170
COP 1838HD+	T38	55	190
COP 2238HD+			

Recommended cable size and length

Voltage	Type	Dimension (mm ²)	Diameter (mm)	Length (m)
380-400 V	Buflex	3x185+3G35	56	90
440-500 V	Buflex	3x150+3G25	52	100
550 V	Buflex	3x120+3G25	46	135
660-690 V	Buflex	3x95+3G16	45	155
1 000 V	Buflex	3x50+3G10	33	200

Recommendations are given for surrounding temperature of 40° C and up to a height of 2 000 m.

Noise and vibration

Operator sound pressure level in canopy, drilling, free field (ISO 11201)	104±6 dB(A) re 20 µPa
Operator sound pressure level in cabin, drilling, free field (ISO 11201)	75±3 dB(A) re 20 µPa
Operator sound pressure level working close to machine, drilling, free field	104±6 dB(A) re 20 µPa
Sound power level (ISO 3744), drilling, free field	128 dB(A) re 1 pW
Vibration levels seated, drilling (ISO 2631-1)	0.07±0.07 m/s ²
Vibration levels standing, drilling (ISO 2631-1)	0.07±0.07 m/s ²

Cabin (optional)

FOPS certified cabin, noise level <80 dB(A), height 3 044 mm including: Air conditioning unit, fixed seat, CD-changer	<input type="checkbox"/>
Protection bars for front window	<input type="checkbox"/>
Heating function for air conditioning (water transferred)	<input type="checkbox"/>
Electrical heater, 1.2 kW, 230 V (CE)	<input type="checkbox"/>
Joystick-controlled spotlights left and/or right	<input type="checkbox"/>

Dimensions in millimeters

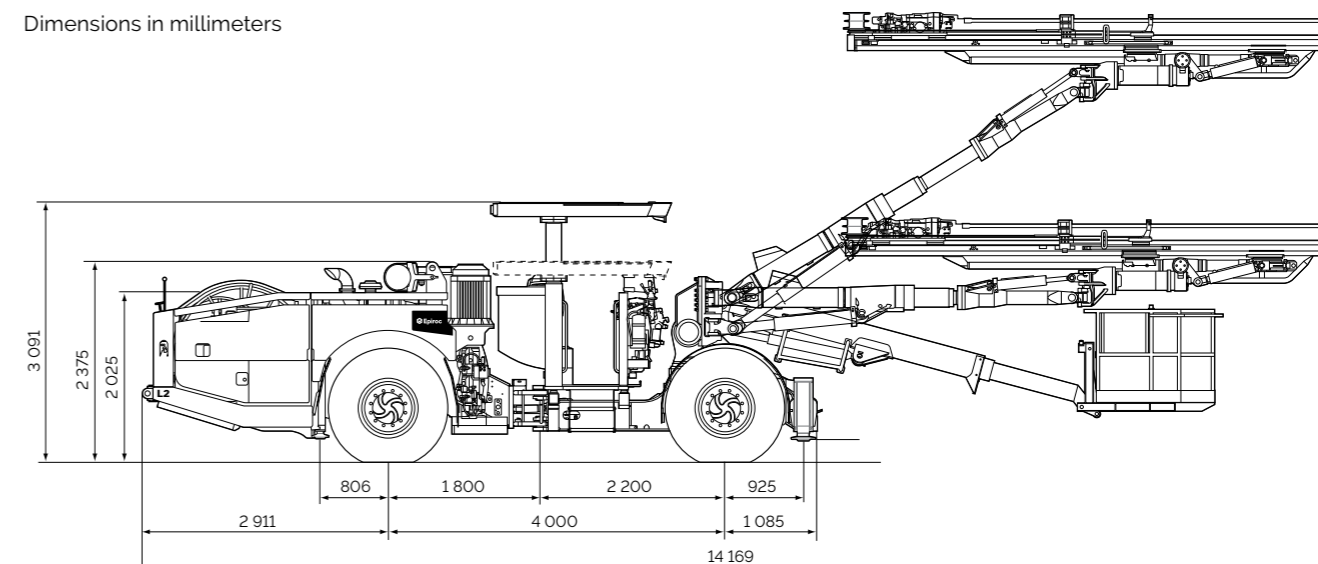
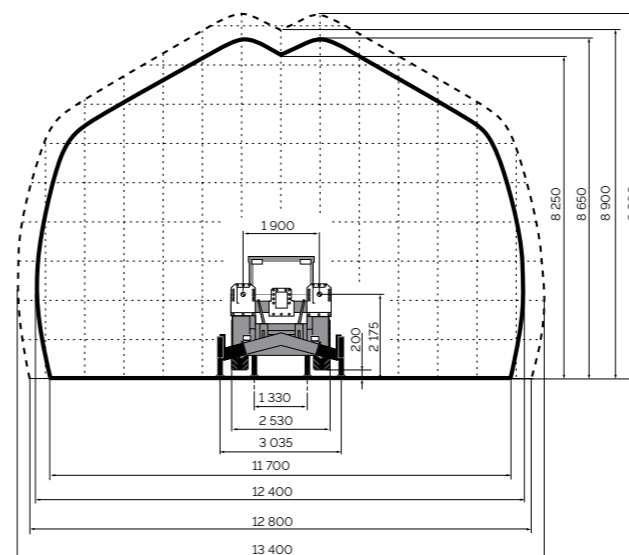
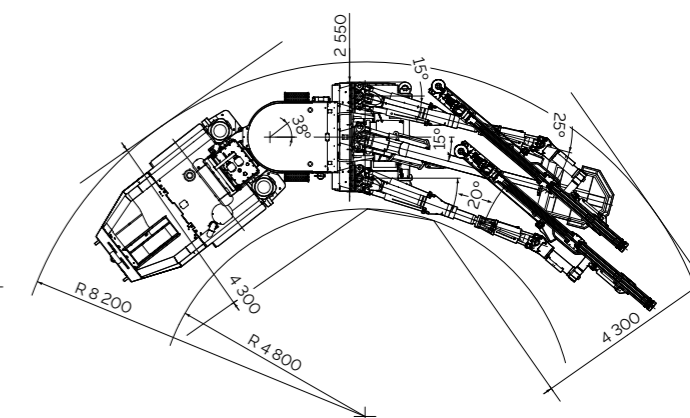

Illustration shows rig with optional equipment mounted.



Coverage area.



Turning radius.



Dimensions

Width	2 550 mm
Height with cabin	3 126 mm
Height roof up/down	3 091/2 375 mm
Length with BMH 6814 feed(s)	14 169 mm
Ground clearance	290 mm
Turning radius outer/inner	8 200/4 800 mm

Tramming speed

On flat ground (rolling resistance 0.05)	>14 km/h
On incline 1:8	>6 km/h

Gross weight (depending on configuration)

Total, min/max	27 000/33 000 kg
Boom side, min/max	20 000/24 000 kg
Engine side, min/max	7 000/9 000 kg

United in performance. Inspired by innovation.

Performance unites us, innovation inspires us, and commitment drives us to keep moving forward. Count on Epiroc to deliver the solutions you need to succeed today and the technology to lead tomorrow.
epiroc.com

